

Figure 1

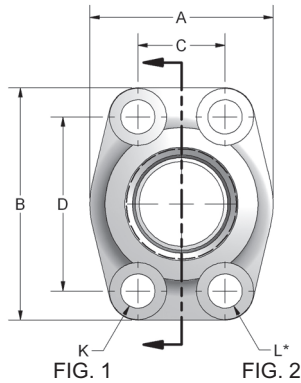

FIG. 1 FIG. 2

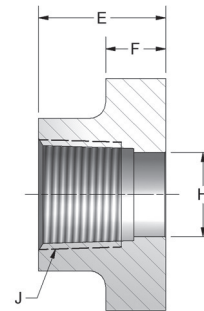

Figure 2

*No Spotface

CODE 61 NPTF THREAD

PART NO. O-RING FIG. 1	PART NO. FLAT FACE FIG. 2	PORT SIZE	PAD SIZE	A	B	C	D	E	F	G	H	J	K	L UNC-2B	MOUNTING HARDWARE	
															O-RING	SHCS
W43-8-8	W104-8-8	.50	.50	1.81	2.13	.688	1.500	1.42	.63	1.000	.502	1/2-14	.344	5/16-18	210	5/16-18X1.25
W43-12-12	W104-12-12	.75	.75	1.97	2.56	.875	1.875	1.42	.71	1.250	.752	3/4-14	.406	3/8-16	214	3/8-16X1.50
W43-16-16	W104-16-16	1.00	1.00	2.17	2.75	1.031	2.062	1.50	.71	1.560	1.002	1-11.5	.406	3/8-16	219	3/8-16X1.50
W43-20-20	W104-20-20	1.25	1.25	2.68	3.12	1.188	2.312	1.61	.83	1.750	1.252	1 1/4-11.5	.469	7/16-14	222	7/16-14X1.75
W43-24-24	W104-24-24	1.50	1.50	3.07	3.66	1.406	2.750	1.77	.98	2.115	1.502	1 1/2-11.5	.531	1/2-13	225	1/2-13X1.75
W43-32-32	W104-32-32	2.00	2.00	3.54	4.00	1.688	3.062	1.77	.98	2.490	2.002	2-11.5	.531	1/2-13	228	1/2-13X1.75
W43-40-40	W104-40-40	2.50	2.50	4.09	4.49	2.000	3.500	1.97	.98	2.995	2.502	2 1/2-8	.531	1/2-13	232	1/2-13X1.75
W43-48-48	W104-48-48	3.00	3.00	4.88	5.28	2.438	4.188	1.97	1.06	3.615	3.002	3-8	.656	5/8-11	237	5/8-11X2.00
W43-56-56	W104-56-56	3.50	3.50	5.35	5.98	2.750	4.750	2.19	1.06	4.095	3.500	3 1/2-8	.656	5/8-11	241	5/8-11X2.00
W43-64-64	W104-64-64	4.00	4.00	5.75	6.38	3.062	5.125	2.19	1.06	4.595	3.940	4-8	.656	5/8-11	245	5/8-11X2.00

CODE 62 NPTF THREAD

PART NO. O-RING FIG. 1	PART NO. FLAT FACE FIG. 2	PORT SIZE	PAD SIZE	A	B	C	D	E	F	G	H	J	K	L UNC-2B	MOUNTING HARDWARE	
															O-RING	SHCS
W44-8-8	W45-8-8	.50	.50	1.81	2.21	.718	1.594	1.42	.63	1.000	.502	1/2-14	.344	5/8-18	210	5/16-18X1.25
W44-12-12	W45-12-12	.75	.75	2.17	2.80	.937	2.000	1.38	.83	1.250	.752	3/4-14	.406	3/8-16	214	3/8-16X1.50
W44-16-16	W45-16-16	1.00	1.00	2.56	3.19	1.093	2.250	1.65	.98	1.560	1.002	1-11.5	.492	7/16-14	219	7/16-14X1.75
W44-20-20	W45-20-20	1.25	1.25	3.07	3.75	1.250	2.625	1.77	1.06	1.750	1.252	1 1/4-11.5	.531	1/2-13	222	1/2-13X1.75
W44-24-24	W45-24-24	1.50	1.50	3.70	4.41	1.437	3.125	1.97	1.18	2.115	1.502	1 1/2-11.5	.656	5/8-11	225	5/8-11X2.25
W44-32-32	W45-32-32	2.00	2.00	4.50	5.28	1.750	3.812	2.56	1.46	2.490	2.002	2-11.5	.781	3/4-10	228	3/4-10X2.75

FLOW, NEEDLE & CHECK VALVES

HYDRAULIC BALL VALVES

WELD COUPLINGS

FLANGES - CARBON STEEL

FLANGES - STAINLESS STEEL