

FLOW, NEEDLE & CHECK VALVES

HYDRAULIC BALL VALVES

WELD COUPLINGS

FLANGES - CARBON STEEL

FLANGES - STAINLESS STEEL

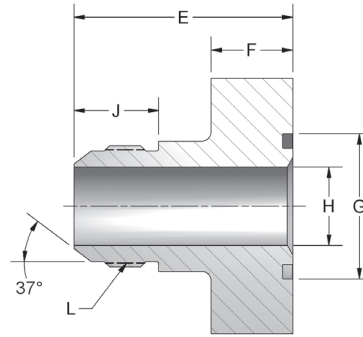
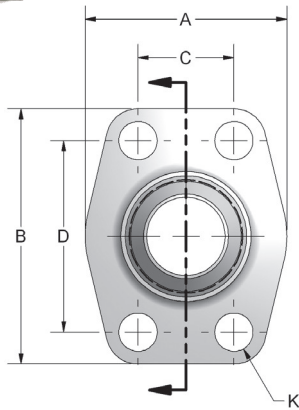
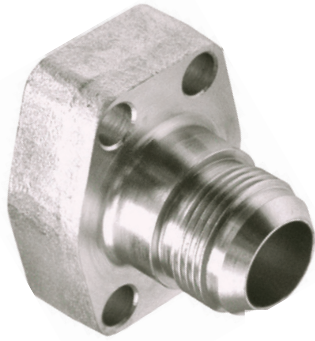

4-Bolt Flange hole pattern per SAE J518. Male JIC Thread per SAE J514.

CODE 61 MALE JIC														
PART NO.	PAD SIZE	A	B	C	D	E	F	G	H	J	K	L	MOUNTING	
													O-RING	SHCS
W300-8-8	.50	1.81	2.13	.688	1.500	2.00	.88	1.000	.394	.657	.344	3/4-16	210	5/16-18X1.25
W300-12-12	.75	1.97	2.56	.875	1.875	2.29	.88	1.250	.611	.864	.413	1 1/16-12	214	3/8-16X1.50
W300-16-16	1.00	2.17	2.75	1.031	2.062	2.35	.88	1.560	.844	.911	.413	1 5/16-12	219	3/8-16X1.50
W300-20-20	1.25	2.68	3.12	1.188	2.312	2.49	.88	1.750	1.078	.958	.469	1 5/8-12	222	7/16-14X1.75
W300-24-24	1.50	3.07	3.66	1.406	2.750	2.81	.98	2.115	1.318	1.083	.531	1 7/8-12	225	1/2-13X1.75
W300-32-32	2.00	3.54	4.00	1.688	3.062	3.25	.98	2.490	1.781	1.333	.531	2 1/2-12	228	1/2-13X1.75

CODE 62 MALE JIC														
PART NO.	PAD SIZE	A	B	C	D	E	F	G	H	J	K	L	MOUNTING	
													O-RING	SHCS
W600-8-8	.50	1.81	2.21	.719	1.594	1.75	.88	1.000	.394	.657	.344	3/4-16	210	5/16-18X1.25
W600-12-12	.75	2.17	2.80	.937	2.000	2.31	.88	1.250	.611	.864	.413	1-1/16-12	214	3/8-16X1.50
W600-16-16	1.00	2.56	3.19	1.093	2.250	2.62	.98	1.560	.844	.911	.492	1-5/16-12	219	7/16-14X1.75
W600-20-20	1.25	3.07	3.75	1.250	2.625	2.81	1.06	1.750	1.078	.958	.531	1-5/8-12	222	1/2-13X1.75
W600-24-24	1.50	3.70	4.41	1.437	3.125	3.25	1.18	2.115	1.318	1.083	.656	1-7/8-12	225	5/8-11X2.25

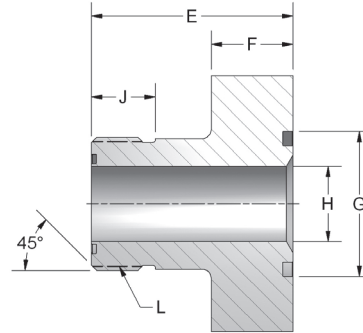
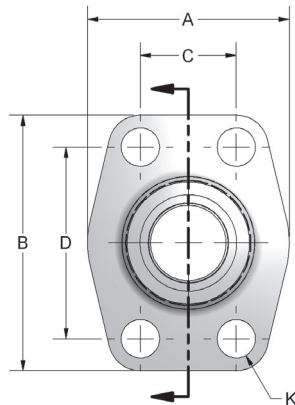
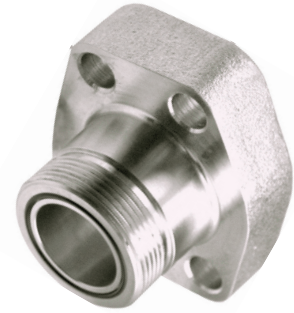

CODE 61 MALE ORFS														
PART NO.	PAD SIZE	A	B	C	D	E	F	G	H	J	K	L	MOUNTING	
													O-RING	SHCS
W304-8-8	.50	1.81	2.13	.688	1.500	1.75	.88	1.000	.394	.504	.344	13/16-16	210	5/16-18X1.25
W304-12-12	.75	1.97	2.56	.875	1.875	2.00	.88	1.250	.611	.670	.413	1 3/16-12	214	3/8-16X1.50
W304-16-16	1.00	2.17	2.75	1.031	2.062	2.00	.88	1.560	.811	.689	.413	1 7/16-12	219	3/8-16X1.50
W304-20-20	1.25	2.68	3.12	1.188	2.312	2.25	.88	1.750	1.024	.689	.469	1 11/16-12	222	7/16-14X1.75
W304-24-24	1.50	3.07	3.66	1.406	2.750	2.50	.98	2.115	1.260	.689	.531	2-12	225	1/2-13X2.00

CODE 62 MALE ORFS														
PART NO.	PAD SIZE	A	B	C	D	E	F	G	H	J	K	L	MOUNTING	
													O-RING	SHCS
W604-8-8	.50	1.81	2.21	.719	1.594	1.75	.88	1.000	.394	.504	.344	13/16-16	210	5/16-18X1.25
W604-12-12	.75	2.17	2.80	.937	2.000	2.25	.88	1.250	.611	.670	.413	1 3/16-12	214	3/8-16X1.50
W604-16-16	1.00	2.56	3.19	1.093	2.250	2.50	.98	1.560	.811	.689	.492	1 7/16-12	219	7/16-14X1.75
W604-20-20	1.25	3.07	3.75	1.250	2.625	2.62	1.06	1.750	1.024	.689	.531	1 11/16-12	222	1/2-13X1.75
W604-24-24	1.50	3.70	4.41	1.437	3.125	2.88	1.18	2.115	1.260	.689	.656	2-12	225	5/8-11X2.25