

FLOW, NEEDLE & CHECK VALVES

HYDRAULIC BALL VALVES

WELD COUPLINGS

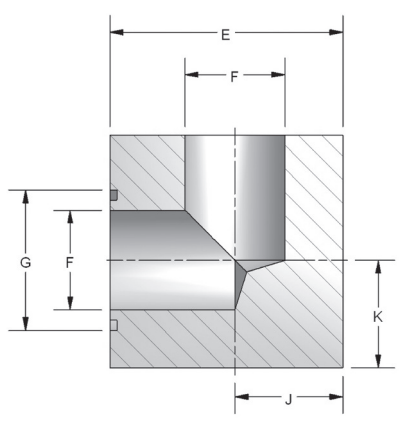
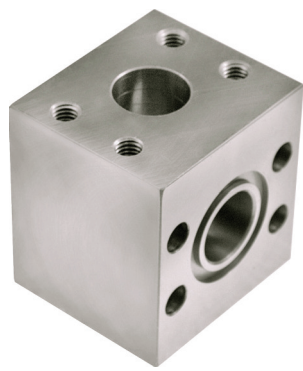

Figure 1

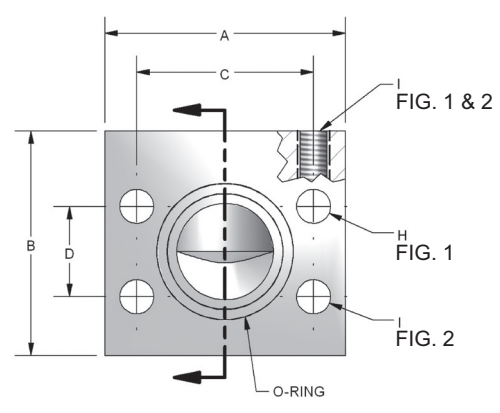

FIG. 1 ONLY

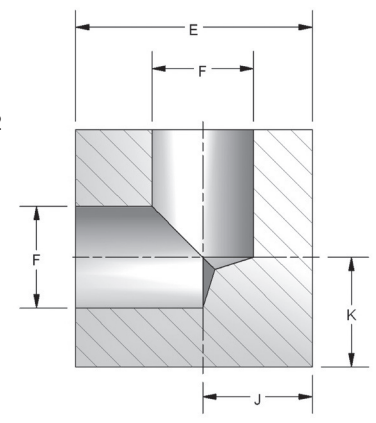

Figure 2

FLANGES - CARBON STEEL

C61 ELBOW BLOCK															
PART NO. O-RING FIG. 1	PART NO. FLAT FACE FIG. 2	PAD SIZE	A	B	C	D	E	F	G	H	I UNC-2B	J	K	MOUNTING HARDWARE	
														O-RING	SHCS
W14-12	W15-12	.75	2.62	2.50	1.875	.875	2.25	.75	1.250	.406	3/8-16	1.03	1.03	214	3/8-16X3.00
W14-16	W15-16	1.00	2.82	2.50	2.062	1.031	2.50	1.00	1.560	.406	3/8-16	1.16	1.09	219	3/8-16X3.25
W14-20	W15-20	1.25	3.19	3.00	2.312	1.188	3.00	1.25	1.750	.469	7/16-14	1.44	1.31	222	7/16-14X4.00
W14-24	W15-24	1.50	3.75	3.50	2.750	1.406	3.50	1.50	2.115	.531	1/2-13	1.62	1.62	225	1/2-13X4.50
W14-32	W15-32	2.00	4.00	4.00	3.062	1.688	4.00	1.94	2.490	.531	1/2-13	1.91	1.91	228	1/2-13X5.00

FLANGES - STAINLESS STEEL

C62 ELBOW BLOCK															
PART NO. O-RING FIG. 1	PART NO. FLAT FACE FIG. 2	PAD SIZE	A	B	C	D	E	F	G	H	I UNC-2B	J	K	MOUNTING HARDWARE	
														O-RING	SHCS
W12-12	W13-12	.75	2.82	2.50	2.000	.937	2.50	.750	1.250	.406	3/8-16	1.19	1.06	214	3/8-16X3.50
W12-16	W13-16	1.00	3.19	3.00	2.250	1.093	3.00	1.00	1.560	.469	7/16-14	1.38	1.38	219	7/16-14X4.00
W12-20	W13-20	1.25	3.75	3.50	2.625	1.250	3.50	1.25	1.750	.531	1/2-13	1.62	1.41	222	1/2-13X4.50
W12-24	W13-24	1.50	4.50	4.00	3.125	1.437	4.00	1.50	2.115	.656	5/8-11	1.88	1.75	225	5/8-11X5.00
W12-32	W13-32	2.00	5.25	5.00	3.812	1.75	5.00	1.94	2.490	.781	3/4-10	2.25	2.50	228	3/4-10X6.00